

Modèle échelle 1/3.3 pour voie de 184mm - 7" 1/4

Cape Government Railways

HAND-OPERATED 6-ton ACCIDENT CRANES

For HOPEFIELD AND AVONTUUR 2ft GAUGE RAILWAYS

Taken From COWANS SHELTON & Co
DRWG N° 5068, 1902
S.Moir 1961

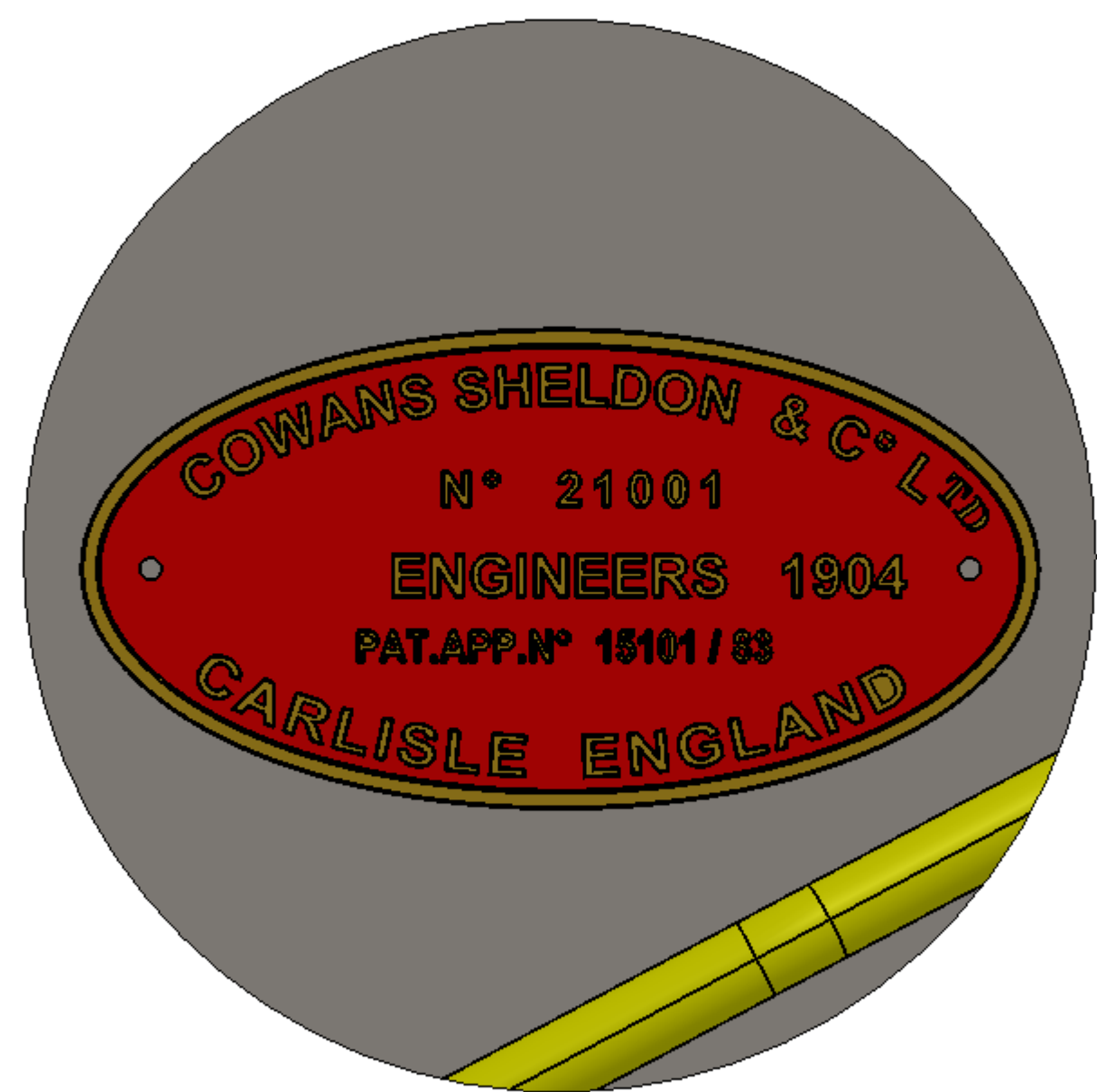
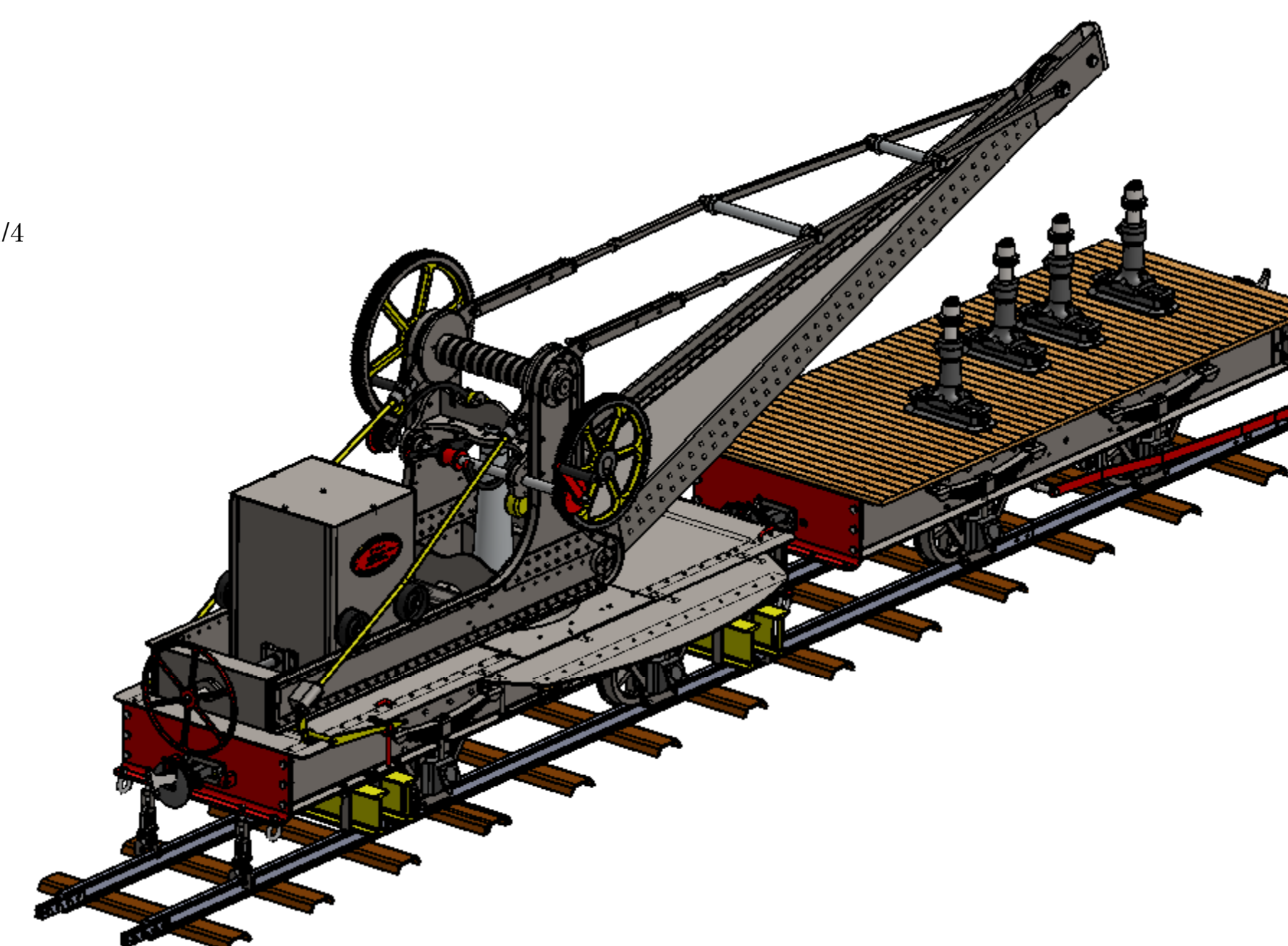

<http://www.letortillard.fr>

SAUF INDICATION CONTRAIRE: LES COTES SONT EN MILLIMETRES TOUTES LES DIMENSIONS SONT EN MILLIMETRES	INVENTOR	CONSTRUCTED ANGLES VPS	REVISIONS REVISIONS
<p>Association "Le Tortillard"</p> <p>Cowans Sheldon 6t</p> <p>convoi grue plateforme A0</p>	<p>DATE</p> <p>REVISIONS</p>	<p>DATE</p> <p>REVISIONS</p>	<p>DATE</p> <p>REVISIONS</p>

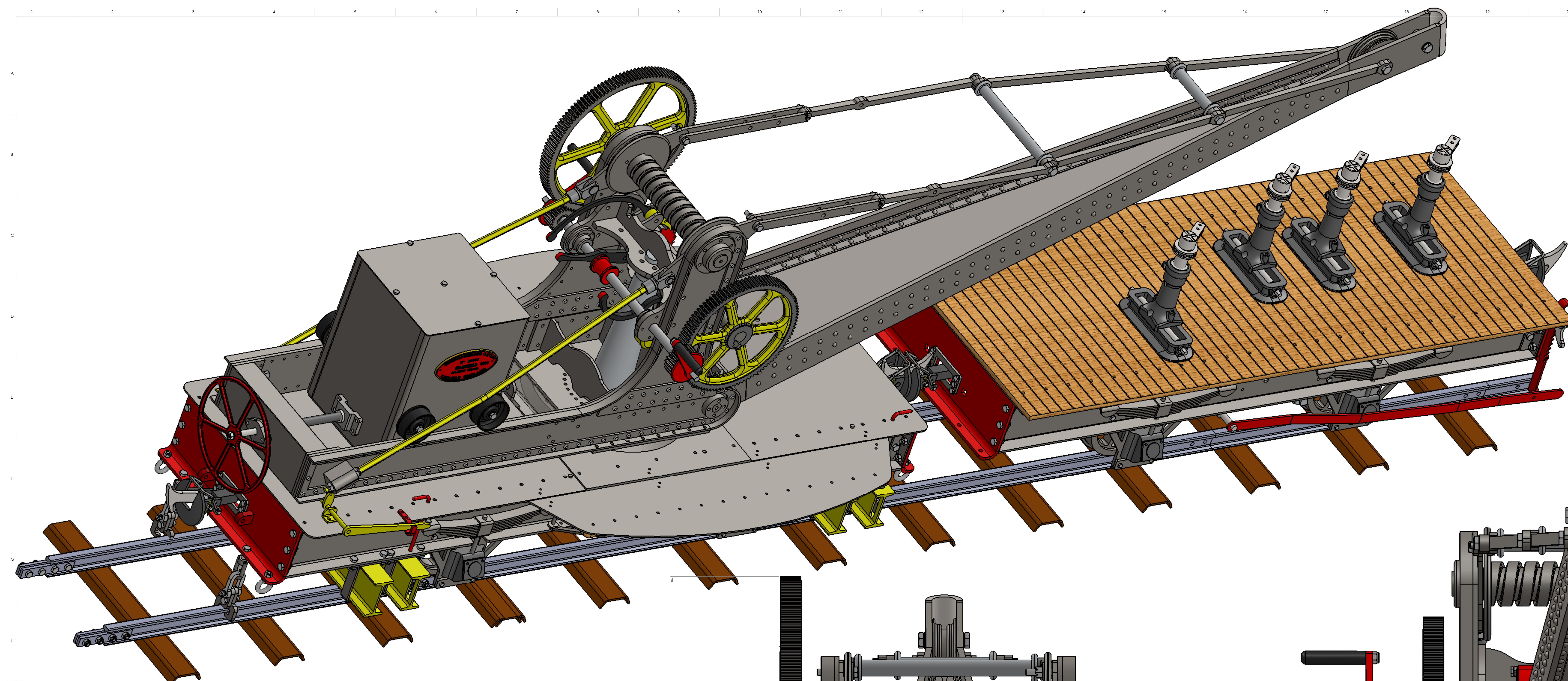

Cape Government Railways
HAND-OPERATED 6-ton ACCIDENT CRANES
 For HOPEFIELD AND AVONTUUR 2ft GAUGE RAILWAYS

Taken From COWANS SHELDON & Co
 DRWG N° 5068, 1902
 S.Moir 1961

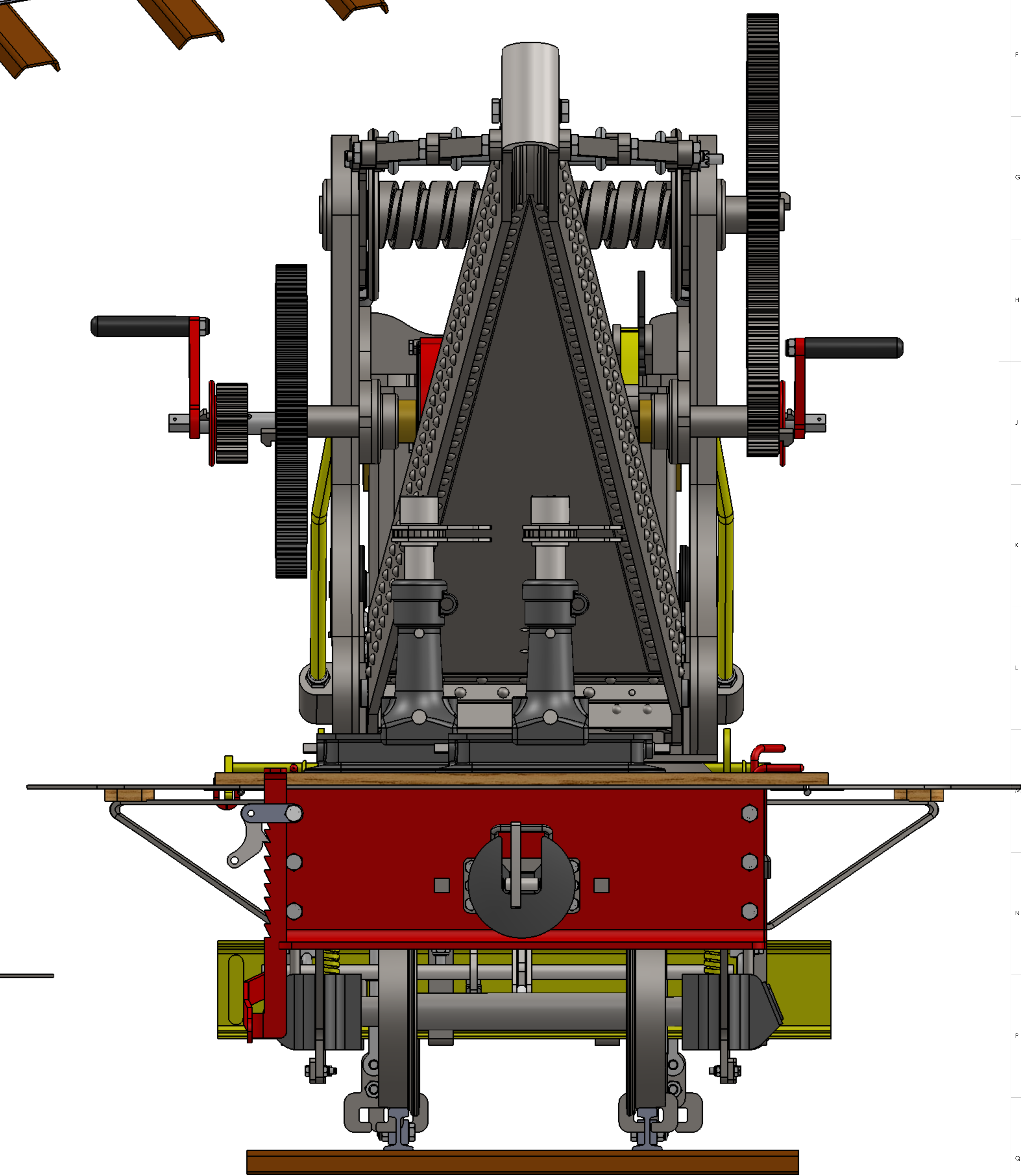
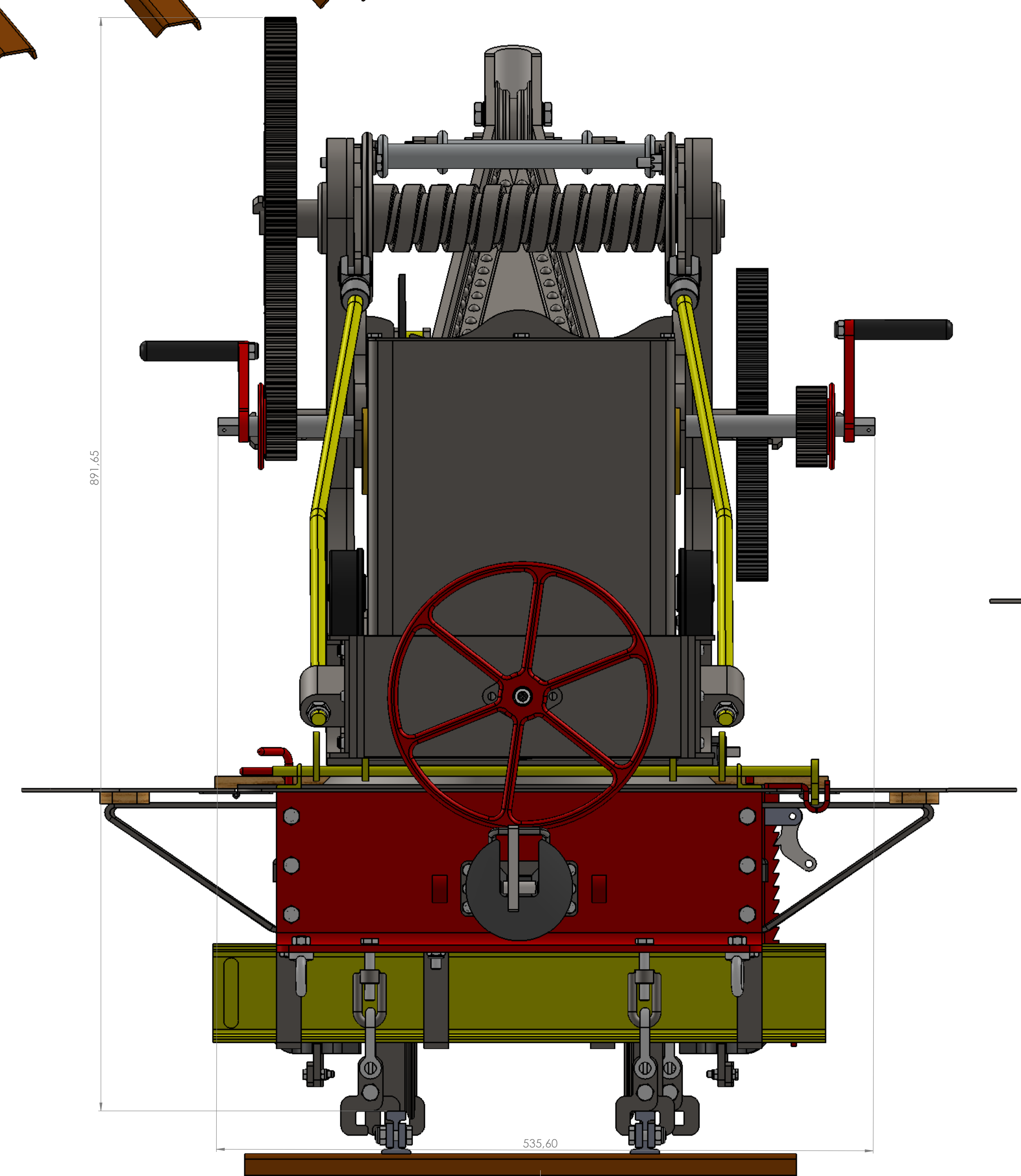

<http://www.letortillard.fr>

SAUF INDICATION CONTRAIRE: LES COTES SONT EN MILLIMETRES TOUTES LES DIMENSIONS SONT EN MILLIMETRES UNLESS OTHERWISE INDICATED: DIMENSIONS ARE IN MILLIMETERS	INFORM.	CAUTIONS ANGLES 45°	REVISIONS
AUTEUR: Moer Nicolas	DATE:	REVISIONS:	Association "Le Tortillard"
PROJ.:	DATE:	REVISIONS:	COWANS & SHELDON 6t
APP.:	DATE:	REVISIONS:	convoi grue plateforme A0
PAB.:	DATE:	REVISIONS:	A0
DATE:	DATE:	REVISIONS:	